



fijaciones

tormetal

LA GAMA MÁS AMPLIA DEL MERCADO

DEXTER, LA MARCA ESPECIALIZADA EN EL SUMINISTRO Y LA GESTIÓN EFICIENTE DE LAS **FIJACIONES** PARA LA INDUSTRIA, PONE A SU DISPOSICIÓN UNA GAMA ÚNICA FORMADA POR UN **EXTENSO ABANICO DE PRODUCTOS ESTÁNDAR Y ESPECIALES** EN LAS **ROSCAS MÁS COMUNES**: MÉTRICA GRUESA, FINA, EXTRA FINA Y EN PULGADAS TIPO **UNC, UNF, BSW Y BSF**. Y EN **DISTINTOS TIPOS DE MATERIALES**: ACERO DESDE CALIDAD 4.6 HASTA 12.9, ACERO INOXIDABLE A1-A2-A4, ALUMINIO, LATÓN, COBRE, TITANIO Y PLÁSTICO. TODAS ELLAS SEGÚN NORMAS **ISO -DIN -ANSI - BS - NF - NEN**.

ACERO Y ACERO INOXIDABLE

- Tornillos de cabeza hexagonal, hexágono interior Allen, tuercas hexagonales, de seguridad, arandelas, espárragos, tornillos rosca chapa
- Se pueden suministrar con distintos tipos de acabado superficial para protegerlos de la corrosión como cincado, bicromatado, pasivado negro, pavonado, galvanizado en caliente, Dacromet®, etc.



NO FÉRRICOS

- Tornillos de cabeza hexagonal, hexágono interior Allen, tuercas hexagonales, de seguridad, arandelas, espárragos, remaches, piezas especiales.



ABRAZADERAS Y ARTÍCULOS DE FIJACIÓN

- Abrazaderas, tuercas especiales, tornillos autoroscantes, posicionadores, engrasadores, pasadores, remaches, chavetas, etc.

PRODUCTOS NO ESTÁNDAR

Fijaciones extra grandes- medidas hasta M100 fabricados bajo normas DIN-ISO-ASTM. También podemos ofrecerle arandelas, tuercas, tornillos, aplicaciones especiales bloqueo-estanqueidad.

CALIDAD

EL ALTO NIVEL DE EXIGENCIA EN LA SELECCIÓN DE NUESTROS FABRICANTES Y LOS ERICTOS CONTROLES A QUE SON SOMETIDOS TODOS LOS PRODUCTOS EN LOS PROCESOS DE RECEPCIÓN Y NUESTROS PROPIOS LABORATORIOS DE CALIDAD, NOS PERMITEN GARANTIZAR QUE **EL PRODUCTO DEXTER CUMPLE CON LOS ESTÁNDARES DE CALIDAD MÁS FIABLES.**



Micrómetros, Calibres pasa/no pasa, Medidor concentricidad



Proyector de perfiles

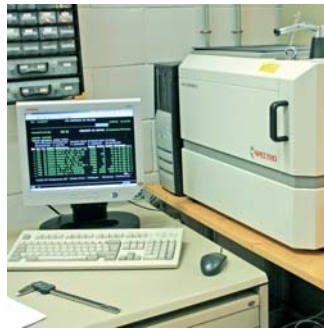

Espectrómetro



Durómetro

PERSONALIZACIÓN DEL SUMINISTRO

· Si lo desean, podemos imprimir su referencia en albaranes, facturas y etiquetas.



· Identificación de artículos con código de barras.

· Suminramos los artículos en un embalaje resistente y apto para almacenar directamente en su almacén. Diferentes tamaños en función de las cantidades servidas.



· SRS - Servicio de Reposición de Stock



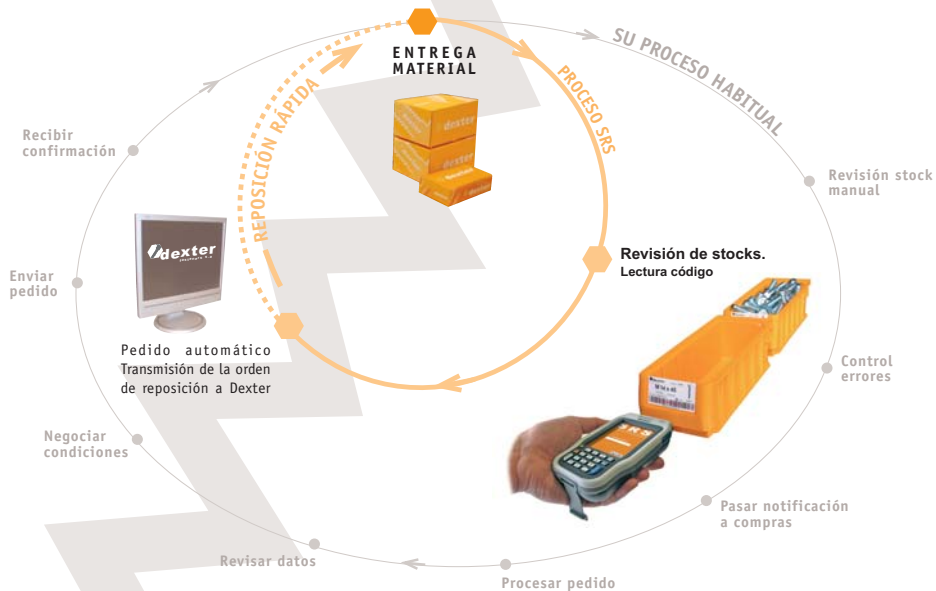













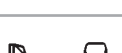

*** reaprovisione su stock con un solo "click"**



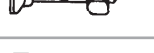

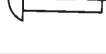





























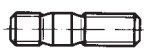





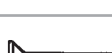

NORMA / ART. N°	FORMA
DIN 1-B ≈ (ISO 2339)	
DIN 7 ≈ (ISO 2338)	
DIN 84 ≈ (ISO 1207)	
DIN 85 ≈ (ISO 1580)	
DIN 93	
DIN 94 (ISO 1234)	
DIN 95	
DIN 96	
DIN 97	
DIN 125-1 A (ISO 7089)	
DIN 125-1 B (ISO 7090)	
DIN 126 (ISO 7091)	
DIN 127-B	
DIN 128-A	
DIN 137-A	
DIN 137-B	
DIN 186-B	
DIN 188	
DIN 258 ≈ (ISO 8737)	
DIN 261	

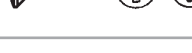
NORMA / ART. N°	FORMA
DIN 315	
≈DIN 315	
DIN 316	
≈DIN 316	
DIN 319-C	
DIN 319-E	
DIN 404	
DIN 417 (ISO 7435)	
DIN 427 (ISO 2342)	
DIN 431-A	
DIN 432	
DIN 433 (ISO 7092)	
DIN 434	
DIN 435	
DIN 436	
DIN 438 (ISO 7436)	
DIN 439-B ≈ (ISO 4035)	
DIN 440-R (ISO 7094)	
DIN 443	
DIN 444-B	

NORMA / ART. N°	FORMA
DIN 444-LB	
DIN 462	
DIN 463	
DIN 464	
DIN 464-SZ	
DIN 466	
DIN 467	
DIN 470	
DIN 471	
DIN 472	
DIN 478	
DIN 479	
DIN 480	
DIN 508 (ISO 299)	
DIN 529-A	
DIN 546	
DIN 551 (ISO 4766)	
DIN 553 (ISO 7434)	
DIN 555 ≈ (ISO 4034)	
DIN 557	

NORMA / ART. N°	FORMA
DIN 561	
DIN 562	
DIN 564-A	
DIN 571	
DIN 580 ≈ (ISO 3266)	
DIN 582	
DIN 601/555 ≈ (ISO 4016)	
DIN 603 ≈ (ISO 8677)	
DIN 604/555	
DIN 605/555	
DIN 607	
DIN 608	
DIN 609	
DIN 653	
DIN 660 ≈ (ISO 1051)	
DIN 661 ≈ (ISO 1051)	
DIN 662 ≈ (ISO 1051)	
DIN 705-A	
DIN 741	
DIN 787 (ISO 299)	

NORMA / ART. N°	FORMA
DIN 835	
DIN 906	
DIN 908	
DIN 910	
DIN 912 (ISO 4762)	
DIN 913 (ISO 4026)	
DIN 914 (ISO 4027)	
DIN 915 (ISO 4028)	
DIN 916 (ISO 4029)	
DIN 917	
DIN 920	
DIN 921	
DIN 923	
DIN 927	
DIN 928	
DIN 929	
DIN 931 ≈ (ISO 4014)	
DIN 933 ≈ (ISO 4017)	
DIN 934 ≈ (ISO 4032)	
DIN 935-1	

NORMA / ART. N°	FORMA
DIN 936 ≈ (ISO 4035)	
DIN 937	
DIN 938	
DIN 939	
DIN 940	
DIN 950	
DIN 960 ≈ (ISO 8765)	
DIN 961 ≈ (ISO 8676)	
DIN 963 ≈ (ISO 2009)	
DIN 964 ≈ (ISO 2010)	
DIN 965 ≈ (ISO 7046)	
DIN 966 ≈ (ISO 7047)	
DIN 975	
DIN 976-1 A	
DIN 979	
DIN 980-V (ISO 7042)	
DIN 981	
DIN 982 ≈ (ISO 7040)	
DIN 985	
DIN 986	

NORMA / ART. N°	FORMA
DIN 988	
DIN ≈ (ISO 8738) 1440	
DIN 1441	
DIN ≈ (ISO 2341) 1444-B	
DIN ≈ (ISO 8739) 1470	
DIN ≈ (ISO 8744) 1471	
DIN ≈ (ISO 8745) 1472	
DIN ≈ (ISO 8740) 1473	
DIN ≈ (ISO 8741) 1474	
DIN ≈ (ISO 8742) 1475	
DIN ≈ (ISO 8746) 1476	
DIN ≈ (ISO 8747) 1477	
DIN 1479	
DIN 1480	
DIN ≈ (ISO 8752) 1481	
DIN 1587	
DIN 1804-W	
DIN 1816-W	
DIN 2093	
DIN 2095	















NORMA / ART. N°	FORMA
DIN 2097	
DIN 2510L/NF	
DIN 2510 NF	
DIN 3404-A	
DIN 3405-A	
ISO ≈ (DIN 931) 4014	
ISO ≈ (DIN 933) 4017	
ISO ≈ (DIN 934) 4032	
DIN 5401	
DIN 5406	
DIN 6319-C	
DIN 6319-D	
DIN (ISO 8734) 6325	
DIN 6330-B	
DIN 6331	
PD 6334	
DIN 6336-K	
DIN 6336-L	
DIN 6340	
DIN 6379	

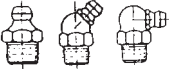
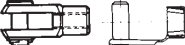

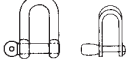



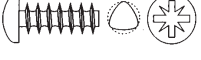
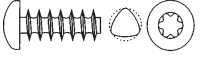
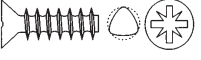
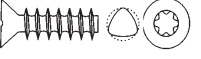
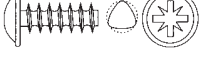
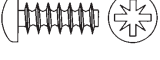



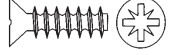

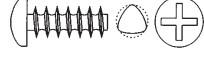
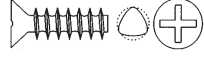





NORMA / ART. N°	FORMA
DIN 6796	
DIN 6797-A	
DIN 6797-J	
DIN 6798-A	
DIN 6798-J	
DIN 6798-V	
DIN 6799	
DIN 6880	
DIN ≈ (ISO 773) 6885-A	
DIN ≈ (ISO 774) 6887	
DIN ≈ (ISO 3912) 6888	
DIN 6899-BF	
≈DIN 6900	
DIN 6911	
DIN 6912	
DIN ≈ (ISO 7412) 6914	
DIN ≈ (ISO 7414) 6915	
DIN ≈ (ISO 7416) 6916	
DIN 6917	
DIN 6918	











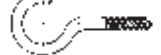
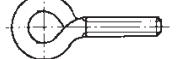



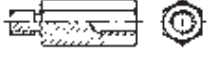

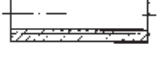
NORMA / ART. N°	FORMA
DIN 6921 ≈ (ISO 6142)	
DIN 6923 ≈ (ISO 4161)	
DIN 6924 ≈ (ISO 7040)	
DIN 6925 ≈ (ISO 7042)	
DIN 6926 ≈ (ISO 7043)	
≈DIN 6928-C (ISO 7053)	
ISO 7089 (DIN 125)	
DIN 7337	
DIN 7343 ≈ (ISO 8750/51)	
DIN 7344 ≈ (ISO 8748)	
DIN 7346 (ISO 13337)	
DIN 7349	
ISO 7379	
ISO 7380	
≈ ISO 7380+AR	
DIN 7500-A	
DIN 7500-C	
≈DIN 7500-CE	
DIN 7500-D	
DIN 7500-E	



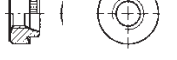
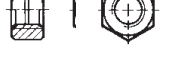







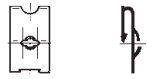

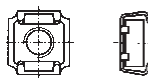
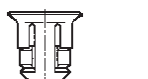
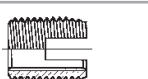
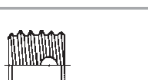
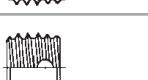
NORMA / ART. N°	FORMA
DIN 7500-M	
DIN 7500-N	
DIN 7504-K	
DIN 7504-N	
DIN 7504-P	
DIN 7513-A	
DIN 7516-A	
DIN 7516-D	
DIN 7516-E	
DIN 7603-A	
DIN 7603-C	
DIN 7604-A	
DIN 7604-C	
DIN 7643	
DIN 7965	
DIN 7967	
DIN 7971-C ≈ (ISO 1481)	
DIN 7971-F ≈ (ISO 1481)	
DIN 7972-C ≈ (ISO 1482)	
DIN 7973-C ≈ (ISO 1483)	





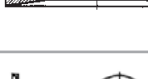







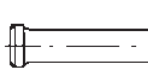



NORMA / ART. N°	FORMA
DIN 7973-F ≈ (ISO 1483)	
DIN 7976-C ≈ (ISO 1479)	
DIN 7976-F ≈ (ISO 1479)	
DIN 7977 ≈ (ISO 8737)	
DIN 7978-A ≈ (ISO 8736)	
DIN 7979-D ≈ (8733/35)	
DIN 7980	
DIN 7981-C ≈ (ISO 7049)	
DIN 7981-F ≈ (ISO 7049)	
DIN 7982-C ≈ (ISO 7050)	
DIN 7982-F ≈ (ISO 7050)	
DIN 7983-C ≈ (ISO 7051)	
DIN 7984	
DIN 7985 ≈ (ISO 7045)	
DIN 7989-A	
DIN 7990	
DIN 7991 ≈ (ISO 10642)	
≈DIN 7991 (ISO 14581/2)	
DIN 7993-A	
DIN 7996	





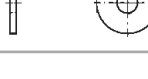





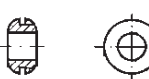
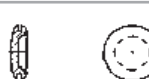

NORMA / ART. N°	FORMA
DIN 7997	
DIN 8140-1 A	
DIN 9021 ~ (ISO 7093)	
DIN 11024	
DIN 15237	
DIN 43699	
DIN 71412	
DIN 71752	
DIN 74361-C	
DIN 82101-A	
NF NF E 25-511	
NF NF E25-513	
NF NF E25-129	
E0205	
E0206	
E0207	
E0208	
E0209	
E0210	
E0211	

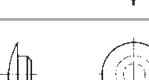
NORMA / ART. N°	FORMA
E0212	
E0213	
E0214	
E0215	
E0216	
E0217	
E0218	
E0219	
E0220	
E0221	
E0222	
E0223	
E0224	
E0225	
E0226	
E0227	
E0228	
E0229	
E0230	
E0231	

NORMA / ART. N°	FORMA
E0232	
E0233	
E0234	
E0235	
E0236	
E0237	
E0238	
E0239	
E0240	
E0241	
E0242	
E0243 IE 117 (Inox)	
E0244	
E0245	
E0247	
E0248	
E0249	
E0250	
E0251	
E0252	

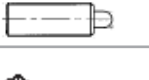
NORMA / ART. N°	FORMA
E0253	
E0254	
E0255	
E0256	
E0257	
E0258	
E0259	
E0260	
E0261	
E0262	
E0263	
E0264	
E0265	
E0266	
E0267	
E0268	
E0269	

NORMA / ART. N°	FORMA
E0270	
E0271	
E0272	
E0273	
IE114	
IE118	
IE120	
IE122	
IE123	
AE100	
AE101	
AE102	
PE100	
PE101	
PE102	
PE104	
PE105	

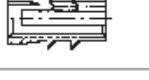
NORMA / ART. N°	FORMA
PE106	
PE107	
PE110	
PE111	
PE112	
PE113	
PE114	
PE116	
PE117	
PE118	
PE119	
IE101 IE102 E0106	
PE148	
LE101	
LE102	
LE103	
LE104	



tormetal

TORNILLERÍA Y DERIVADOS METÁLICOS, S. A.
C/ Comerç, 11 - Polígono Industrial La Ferreria
08110 Montcada i Reixac - Barcelona
Tel: 93 564 57 62 - Fax: 93 564 54 69 - info@tormetal.com